

# Inverted Pursuits Lab

## **Featherweight Capsule**

### Parts:

#### 3D Printed

- Top Cover (IP121401)
- Mid Plate (IP121402)
- Bottom Cover (IP121403)

#### Standard Parts

- 4-40 x 1/4
- 4-40 x 3/8
- 4-40 x 1/2

#### Full instructions available online

<https://inverted-pursuits-lab.square.site/downloads>

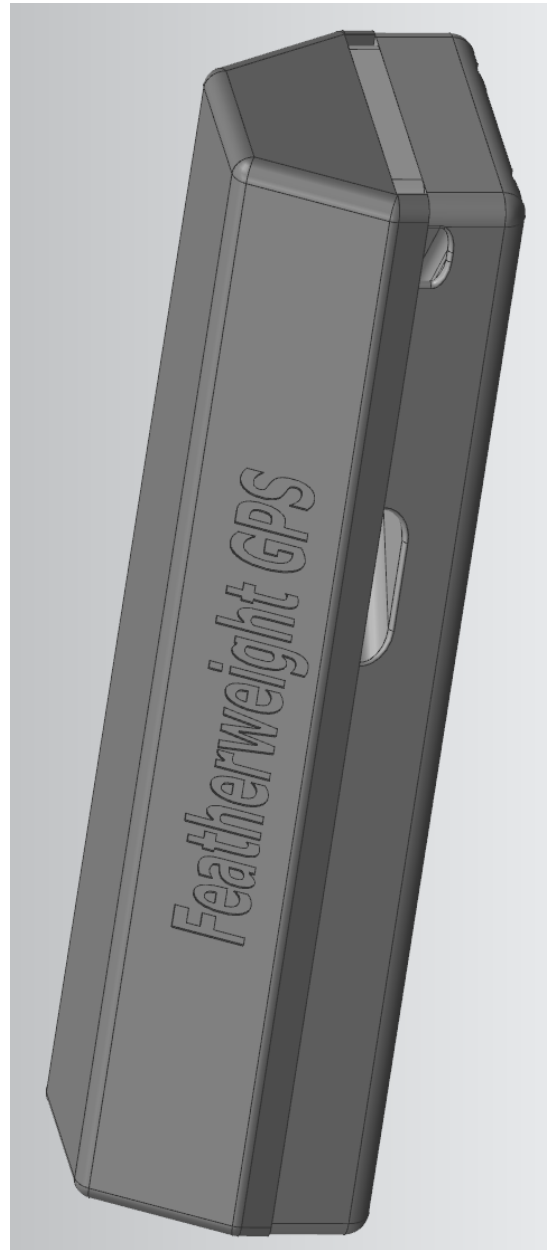
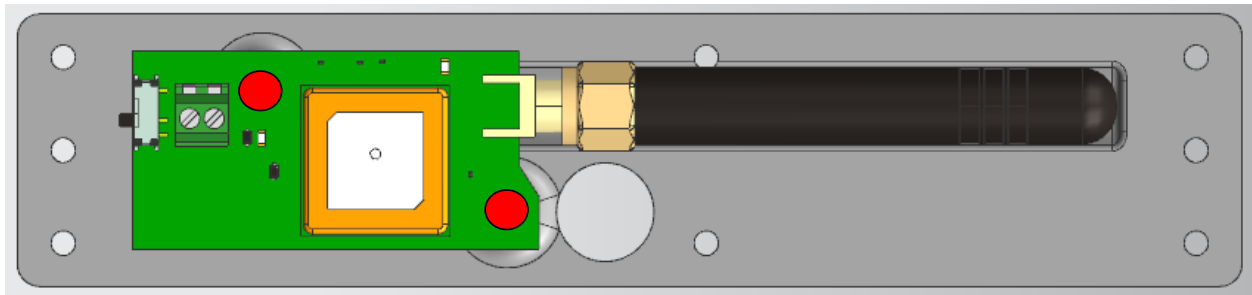

FIGURE 1: Featherweight Capsule

## Assembly Instructions

1. An assembly video is available on YouTube at Inverted Pursuits Laboratory
2. Be sure to test fit and sand all components that interfere prior to proceeding.
3. Mount the Featherweight GPS unit to the Mid Plate with 2x 4-40 x 1/4in screws (Shown in red)



4. Next fish the battery cable through the battery hole and plug into the featherweight unit

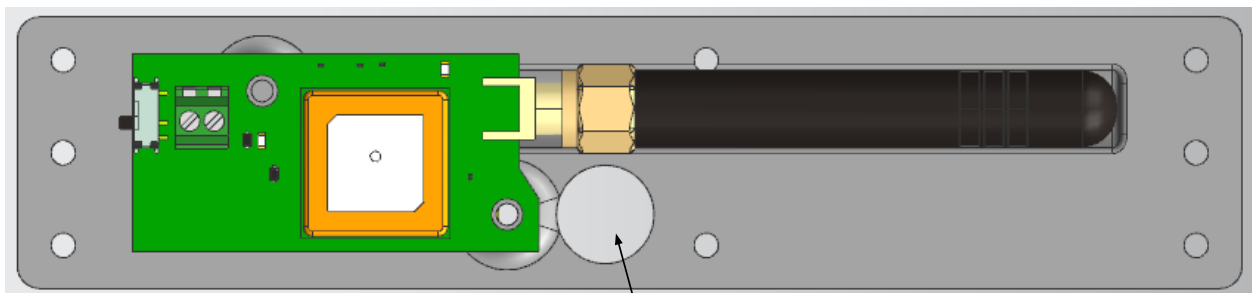

BATTERY PASS  
THROUGH

5. Power on the Featherweight GPS unit before proceeding
6. Mount the Top Cover with 2x 4-40 x 3/8in screws (Shown in Orange)

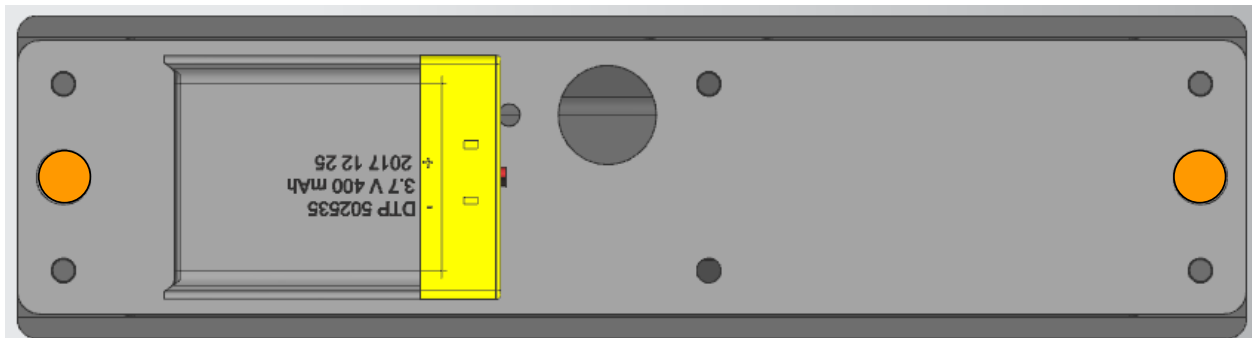

7. Set the battery into the battery slot in the bottom cover and secure the shock cord inside its slot.

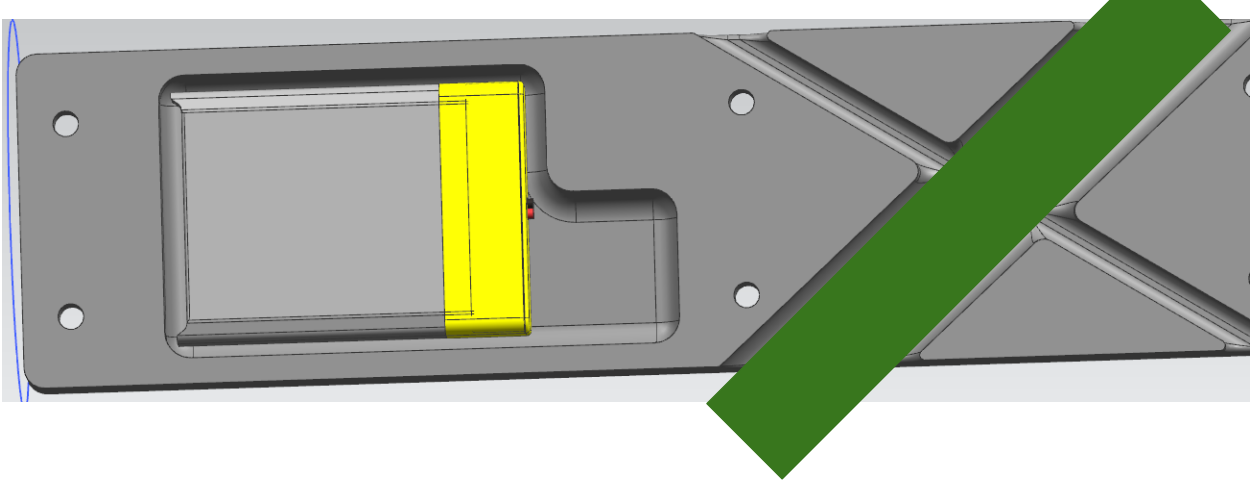

8. Screw the Bottom Cover to the Capsule assembly with 5x 4-40 x 1/2in screws and 1x 4-40 x 3/8in screw



9. Once assembly is finished enjoy flying

